



CONSOLIDATED
ENERGY

HAIER DUCTED

AIR CONDITIONING

CONSOLIDATEDENERGY.COM.AU

Smart Power Ducted and Cassette Inverter Air Conditioning Systems



Haier
Air Conditioning





Haier Brand Story

The Internet era is a diverse and unconventional time, where "one size fits all" products and solutions simply aren't enough. Customers want to be treated as individuals and respected for who they are.

Everyone wants their unique lifestyle acknowledged. That is why Haier listens closely to you in order to gain a genuine understanding of what is going on in your life and what is on your mind, so each of you can get the smart home experience you deserve: be it simple, sophisticated, organised or enjoyable.

As a worldwide industry leader, Haier innovates beyond products and solutions and turns the organisation into a wholly connected platform. In doing so, internal and external resources are connected quickly and easily. We believe only by doing so can we best meet our consumers' expectations in this rapidly evolving world.

Be part of the Haier Network, and create new possibilities.

ENERGY



Demand Response Enabling Device. Compatibility to connect the power supply company device which will reduce peak demand to the power supply network at critical peak load times.



DC inverter A-PAM inverter 180° sine wave inverter technology will reduce vibration and noise at low compressor frequency when compared to a standard inverter system.



Latest technology DC motor is adopted instead of traditional AC motor. DC motor consumes less power to operate versus a typical AC motor and has a built-in microprocessor for programmability and better control.



On/Off control card can be managed by a simple on/off device such as a hotel card system.



Minimum Energy Performance Standards (MEPS) Conforms to Australian and New Zealand Standard AS/NZS3823.2.2013.

TECHNOLOGY



Connection of more than one indoor unit so they can operate as a group.



Connection to an accessory central control device to allow independent operation of more than one device at a central location.



Built in timer



Prevent unauthorised operation

CONVENIENCE



Compact design. The design was optimised to be compact in height



Condensate water pump. The product has a inbuilt condensate water pump that will pump the condensate water up and allowing it to drain away in areas where gravity drain is unavailable.



Adjustable ESP (External static pressure) With the adoption of DC fan motor the ESP can be set via the remote controller saving installation time.



Pipe connection inside cabinet for a smooth exterior



Condensate connection (gravity drain) on either ends of the cabinet



Condensate connection (gravity drain) has two connections. A safety pan is supplied fitted to the indoor unit

ICON LEGEND

COMFORT



Built-in microprocessor automatically detects room temperature and determines operation mode either heating or cooling.



Control via smart phone or tablet which can connect to the Internet



Adoption of DC fan motor permits 4 fan speed control by the user.



Temperature requirement shift during sleep as we remain inactive. The system will adjust temperature and noise for a more comfort during sleep.



Dry Mode concentrates on RH% humidity reduction and less on temperature.



4 way independent airflow. Each side can be controlled separately to customise to your space.



Round way airflow. Specially designed facia grille that allows airflow out of the corners as well as the sides to attempt to distribute air in a 360 degree pattern.



Fresh air duct connection.

RELIABILITY



Outdoor unit designed for cooling up to 50 °C



Outdoor unit designed for heating operation down to - 20 °C



Outdoor Unit designed for cooling operation down to - 15 °C



The heat exchanger aluminium fin stock has a Hydrophilic coating for its anti- corrosion properties and its low surface tension which enables water droplets to flow off the surface better than standard Aluminium fin.



Designed for both 50 and 60Hz power supply.



Allows the system pressures to balance before attempting start of the compressor to prevent damage and excessive power consumption.



Auto restart after power failure in the event of a power outage.



Self diagnosis function; In the event of failure an error code will be displayed.

Haier AC Milestones



30 Years Providing Better Air Solution

A history of bringing valued products to market around the world

1984
Haier group was founded in Qingdao, China



1985
Qingdao Qingkong air conditioner factory established.
Haier manufactures China's 1st split air conditioner



1993
Haier introduces China's first inverter air conditioner



1994
Haier receives ISO 9001 certification
Haier exports its first air conditioners to Europe



1996
Haier introduces full range light commercial air conditioning solution



1998
Haier introduces the first DC inverter air conditioner in China



1999
Haier begins export of air conditioners to the United States and reaches #1 brand status for Room and Portable Air Conditioners in 2005



2001
Haier builds up industry park in Pakistan and catches No.1 market share in 2005



1984

1985

1993

1994

1996

1998

1999

2001

2002

Haier adds portable air conditioner to the US



2006

Haier releases R410a DC inverter VRF system



Haier releases centrifugal chiller with maglev technology



2007

Haier achieves the bid of 20 projects of Beijing Olympic Games



2011

Haier introduces full range of Super match solution covering on-off and inverter models as well as mono and multi system



Super match

2014

Haier establish AC R&D center to enhance the R&D ability with more focus on user's experience



2015

Haier build up the world's most advanced intelligent factory



2016

Haier launches Smart Power high efficiency air conditioning system



2002

2006

2007

2011

2014

2015

2016



SMART POWER



- Key features
- Low Profile Ducted
- High Static Ducted
- Cassette
- Drawings
- Control systems



KEY



Wi-Fi



It is simple to make the Haier Smart Power System Wi-Fi compatible. Purchase the additional accessory KZW-W001 and connect it to the indoor unit. Then control your Haier System wherever you are by smart phone or tablet.

The Wi-Fi module (KZW-W001) will connect to the internet via your Wi-Fi router (WiFi router not supplied).

Download the Haier smart Air 2 APP free from apple or android stores.

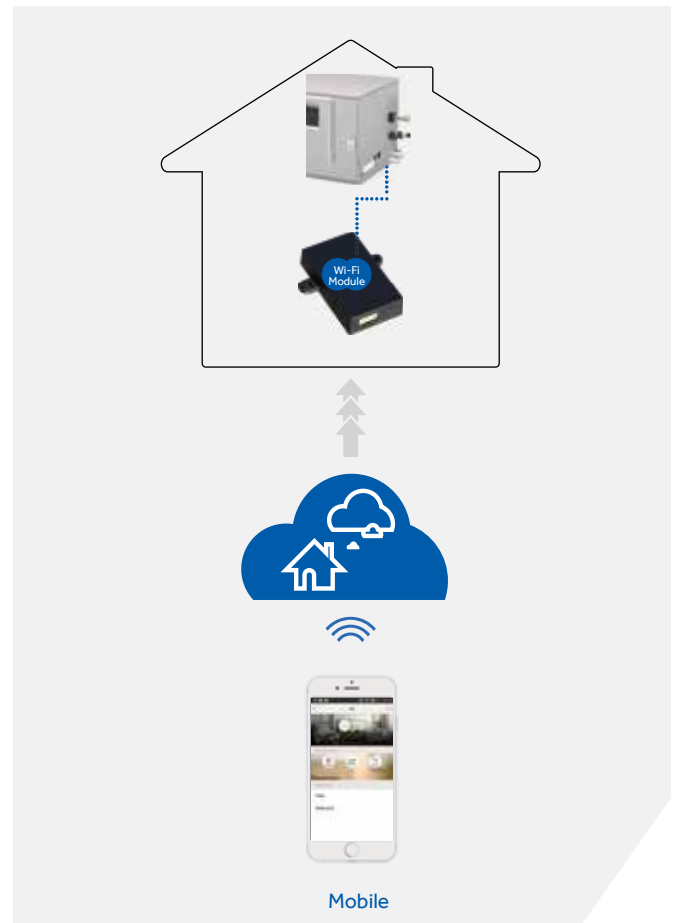

FEATURES



Corrosion protection

Haier evaporator adopts new generation blue aluminium fin which specializes in strong corrosion resistance and super hydrophilic performance.



"888" digital test panel

All running parameters and error code can be checked from the "888" digital display. Simpler operation to reduce diagnosis time.

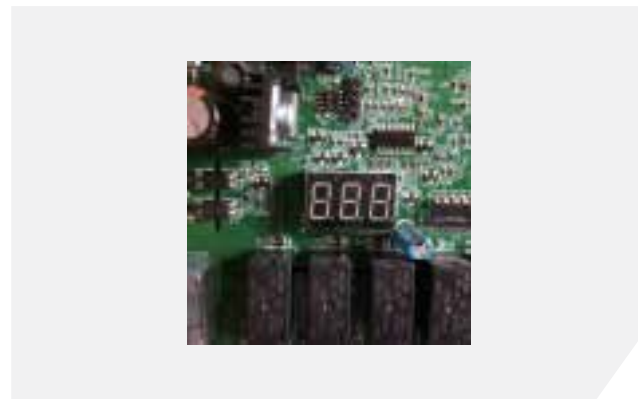

Low Sound Level

Lower sound level can be achieved by an industry leading 550 mm fan and unique outlet grille. The new grille design offers less resistance to airflow and less noise.

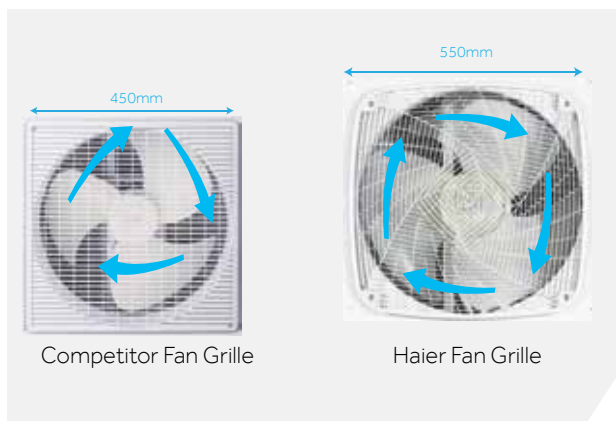

Handles for easier transporting

Four handles are designed into each outdoor unit to allow for two people to carry.





DC fan Motor

In most cases a DC motor uses less energy than a standard AC motor. The greater qty of fan speed in a DC motor allows for better airflow fine tuning, for easier commissioning.

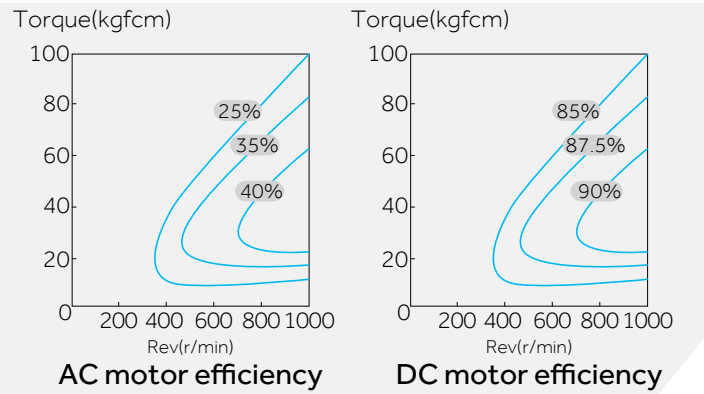

Adjustable Static Pressure

The wired controller has special menu's to make simple adjustments to the external static pressure in order to maintain airflow as required. Static can be changed on the wired RC from 30 to 120 Pa (model dependant)

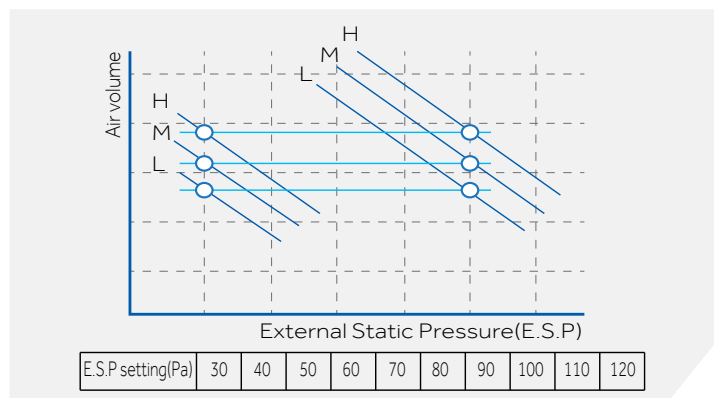

Consistent airflow

The indoor units contain up to 3 fans which can provide consistent airflow in different ductwork installations. Haier test has proven no loss in airflow at increased static pressure .installations.

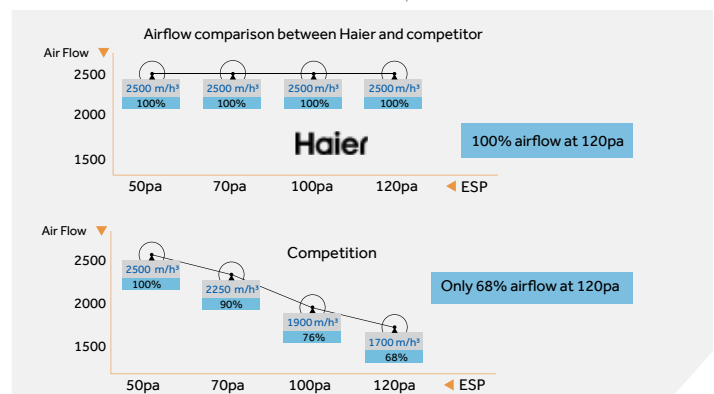

LOW PROFILE DUCT



High lift drain pump

Condensate water lift up to 1000mm which will allow for a flexible installation

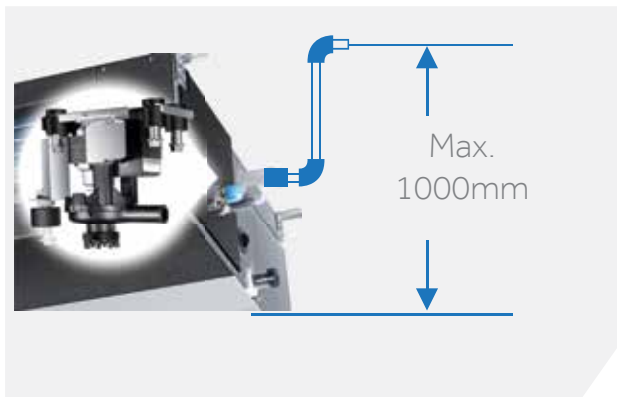

Return air choices

Friendly design: Rear air return or bottom air return is available. The indoor unit is supplied as rear return air design, but with a simple panel change the unit can be field converted to a bottom return air.



Left or right drain outlet

Gravity drain connections are provided on the left or right. Additionally there is a drain pump outlet next to the electrical panel side.

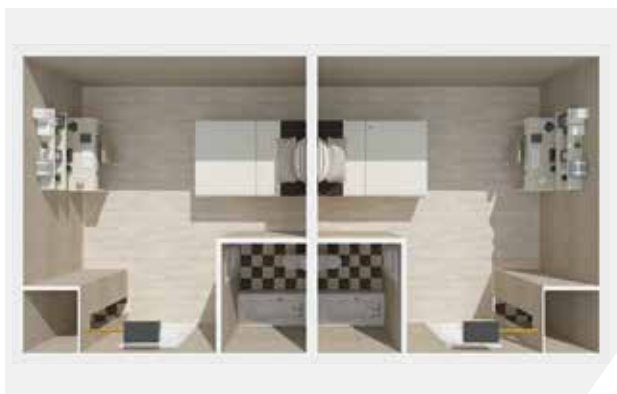

Super slim

Ultra slim design, the height of the medium static ducted indoor unit is 250mm only. Designed to fit into spaces where a normal ducted system is not suitable.



LOW PROFILE DUCTED



🇬🇧 ADH071M1ERG 🇮🇹 ADH090M1ERG 🇬🇧 ADH105M1ERG



YR-E17



7.1kW, 9.0kW



10kW

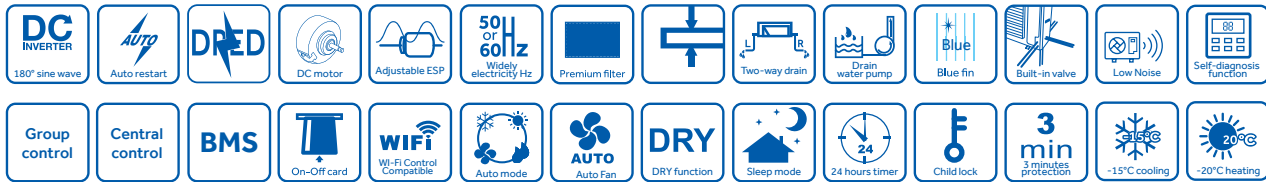

Model		Indoor unit	ADH071M1ERG	ADH090M1ERG	ADH105M1ERG	
		Outdoor unit	1UH071N1ERG	1UH090N1ERG	1UH105N1ERG	
Nominal performance data	Capacity	Cooling	kW Nom (min-max)	7.1 (2.0-9.0)	8.5 (2.5-10)	10.0 (2.5-11)
		Heating	kW Nom (min-max)	8.0 (2.0-10.0)	9.5 (2.5-11)	10.4 (2.5-12)
	Rated power input	Cooling	kW Nom (min-max)	2.03 (0.4-4.0)	2.50 (0.5-4.4)	2.93 (0.5-4.5)
		Heating	kW Nom (min-max)	2.0 (0.4-4.0)	2.50 (0.5-4.4)	2.97 (0.5-4.5)
	EER			3.5	3.4	3.4
COP			4.0	3.8	3.5	
Indoor Unit						
Electrical	Power supply	Ph/V/Hz	1/220-240/50/60			
Performance	Air flow (H/M/L)	m3/h	1050/840/630	1300/900/700	2000/1740/1380/1280	
		L/S	290/230/175	360/250/190	555/480/380/355	
	External Static Pressure	pa	10/30/50/70	10/30/50/70	30 to 120	
	Sound power level (H/M/L)	dB(A)	58	60	55	
Installation	Sound pressure level (H/M/L)	dB(A)	38/35/32	40/37/34	32/28/25/23	
	External dimensions (HxWxD)	mm	957x655x250		1500x700x250	
	Shipping dimensions (WxDxH)	mm	1170x860x340		1710x865x320	
	Net/Shipping weight	kg	31.2/36.8		49/61	
	Supply air Flange	mm	145x800		168x1286	
	Return Air Flange	mm	235x851		235x1435	
	Wired Controller		Standard	YR-E17		
		Optional	YR-E16A (7 day time clock)			
Outdoor Unit						
Electrical	Power supply	Ph/V/Hz	1/220-240/50/60			
	Rated Current	Cooling	Amps	8.7	11.1	13.6
		Heating	Amps	9.1	11.1	12.7
Maximum Current		Amps	17.5	19.2	21	
Performance	Air flow (H)	m3/h	3200	3500	4000	
		L/S	890	975	1115	
	Sound power level	dB(A)	64	66	68	
	Sound pressure level	dB(A)	47	50	52	
Installation	External dimensions (HxWxD)	mm	965x950x370			
	Shipping dimensions (HxWxD)	mm	1095x1050x450			
	Net/Shipping weight	kg	80/92		82/94	
	Compressor type		Twin rotary			
	Refrigerant type		R410A			
	Refrigerant liquid pipe	mm	9.52			
	Refrigerant gas pipe	mm	15.88			
	Max pipe length	m	50			
	Max height between I.U.&O.U	m	30			
	Refrigerant pre-charged	kg	2.5			
	Pre-charged line length	m	20			
	Additional gas charge	g/m	45			
	Working temp.	Cooling (Min-Max)	°C	-15 to +50		
Heating (Min-Max)		°C	-20 to +24			

LOW PROFILE DUCTED



ADH125M1ERG ADH140M1ERG



YR-E17



12.5kW, 14kW

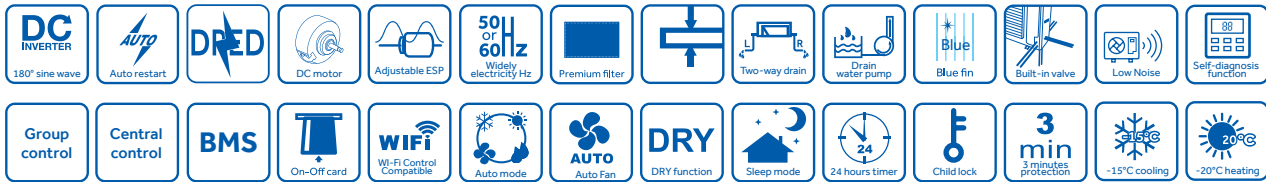

Model		Indoor unit	ADH125M1ERG	ADH140M1ERG	ADH125M1ERG	ADH140M1ERG	
		Outdoor unit	1UH125P1ERG	1UH140P1ERG	1UH125P1ERG	1UH140P1ERG	
Nominal performance data	Capacity	Cooling	kW Nom (min-max)	12.5 (3.5-15.0)	13.4 (3.5-16.0)	12.5 (3.5-15.0)	13.4 (3.5-15.5)
		Heating	kW Nom (min-max)	13.7 (4.0-18.0)	15.0 (4.0-19.0)	13.7 (4.0-18.0)	15.0 (4.0-19.0)
	Rated power input	Cooling	kW Nom (min-max)	3.67 (1.0-6.5)	4.05 (1.0-6.5)	3.67 (1.0-6.5)	4.05 (1.0-6.5)
		Heating	kW Nom (min-max)	3.91 (1.0-6.5)	4.29 (1.2-6.5)	3.91 (1.0-6.5)	4.29 (1.2-6.5)
	EER			3.4	3.3	3.4	3.3
COP			3.5	3.5	3.5	3.5	
Indoor Unit							
Electrical	Power supply	Ph/V/Hz	1/220-240/50/60		1/220-240/50/60		
Performance	Air flow (H/M/L)	m ³ /h	2250/1960/1680/1500	2500/2160/1780/1500	2250/1960/1680/1500	2500/2160/1780/1500	
		L/S	625/540/465/415	690/600/490/415	625/540/465/415	690/600/490/415	
	External Static Pressure	pa	30 to 120		30 to 120		
	Sound power level (H/M/L)	dB(A)	62	64	62	64	
	Sound pressure level (H/M/L)	dB(A)	39/36/33/31	41/36/33/31	39/36/33/31	41/36/33/31	
Installation	External dimensions (WxDxH)	mm	1500x700x250				
	Shipping dimensions (WxDxH)	mm	1710x865x320				
	Net/Shipping weight	kg	52/63				
	Supply air Flange	mm	168x1286				
	Return Air Flange	mm	235x1435				
	Wired Controller	Standard	YR-E17				
	Optional	YR-E16A (7 day time clock)					
Outdoor Unit							
Electrical	Power supply	Ph/V/Hz	1/220-240/50/60		3/380-415/50/60		
	Rated Current	Cooling	Amps	17.0	18.0	6.1	7.0
		Heating	Amps	17.5	19.0	6.5	7.3
	Maximum Current	Amps	30.0	32	10.8	11.0	
Performance	Air flow (H)	m ³ /h	6500	7000	6500	7000	
		L/S	1810	1945	1810	1945	
	Sound power level	dB(A)	69	70	69	70	
	Sound pressure level	dB(A)	52	53	52	53	
Installation	External dimensions (HxWxD)	mm	1350x950x370				
	Shipping dimensions (HxWxD)	mm	1500x1090x480				
	Net/Shipping weight	kg	108/121				
	Compressor type		Twin rotary				
	Refrigerant type		R410A				
	Refrigerant liquid pipe	mm	9.52				
	Refrigerant gas pipe	mm	15.88				
	Max pipe length	m	75				
	Max height between I.U.&O.U	m	30				
	Refrigerant pre-charged	kg	3.7				
Pre-charged line length	m	30					
Additional gas charge	g/m	45					
Working temp.	Cooling (Min-Max)	°C	-15 to +50				
	Heating (Min-Max)	°C	-20 to +24				



Design

The 10.5- 16kW indoor unit design was optimised to ensure the compact indoor unit was kept to a maximum of only 550mm. Ideal for 600mm truss spacing of a normal house.



DC Fan Motor

In most cases a DC motor uses less energy than a standard AC motor. A DC motor allows for better airflow fine tuning by having more speed options which allows for easier commissioning.

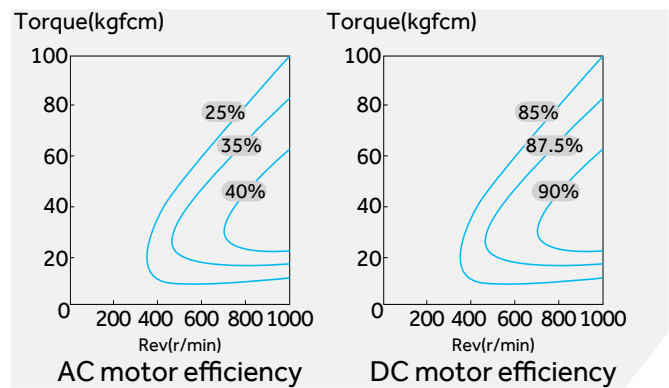

Safety Drain Tray Built In

The 10.5 to 16 kW indoor unit is designed to incorporate two drain trays for condensate removal. The secondary tray is a backup in case the first one overflows due to a blockage.



HIGH STATIC DUCT



Serviceability

Top, bottom or side panels are removable for servicing and installation (10,5 - 16 kW)



10 step adjustments of ESP

ESP can be adjusted by wired controller YR-E17/YR-E16. The installer has no need to open the electrical box and adjust the ESP by switch or plug, reducing installation time.



Wi-Fi

The Wi-Fi module (KZW-W001 purchased separately) can connect to the internet via your Wi-Fi router. The Haier smart Air 2 APP is available free for apple or android devices.

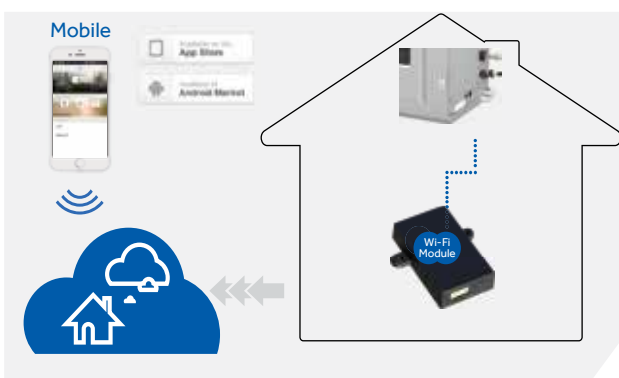

HIGH STATIC DUCTED



ADH071M3ERG



YR-E17



7.1kW

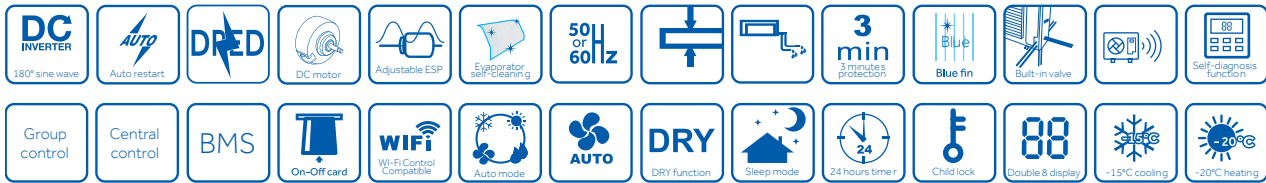

Model		Indoor unit		ADH071M3ERG
		Outdoor unit		1UH071N1ERG
Nominal performance data	Capacity	Cooling	kW Nom (min-max)	7.1 (2.0-9.0)
		Heating	kW Nom (min-max)	8.0 (2.0-10.0)
	Rated power input	Cooling	kW Nom (min-max)	2.03 (0.4-4.0)
		Heating	kW Nom (min-max)	2.0 (0.4-4.0)
	EER			3.5
COP			4.0	
Indoor Unit				
Electrical	Power supply		Ph/V/Hz	1/220-240/50/60
Performance	Air flow (H/M/L)		m ³ /h	1450/1200/950/700
			L/S	402/333/263/194
	External Static Pressure		pa	25-150
	Sound power level (H/M/L)		dB(A)	58
Installation	Sound pressure level (H/M/L)		dB(A)	38/35/32/29
	External dimensions (WxDxH)		mm	957x655x250
	Shipping dimensions (WxDxH)		mm	1170x860x340
	Net/Shipping weight		kg	31.2/36.8
	Supply air Flange		mm	145x800
	Return Air Flange		mm	235x851
	Wired Controller		Standard	YR-E17
		Optional	YR-E16A (7 day time clock)	
Outdoor Unit				
Electrical Parameters	Power supply		Ph/V/Hz	1/220-240/50
	Rated Amps	Cooling	Amp	8.8
		Heating	Amp	9.2
	Maximum Amps	Cooling	Amp	17.5
Heating		Amp	17.5	
Performance	Air flow (H)		m ³ /h	3200
	Sound power level		dB(A)	64
	Sound pressure level		dB(A)	47
Installation	External dimensions (HxWxD)		mm	965x950x370
	Shipping dimensions (HxWxD)		mm	1095x1050x450
	Net/Shipping weight		kg	80/92
	Compressor type			Twin rotary
	Refrigerant type			R410A
	Refrigerant liquid pipe		mm	9.52
	Refrigerant gas pipe		mm	15.88
	Max pipe length		m	50
	Max height between I.U.&O.U		m	30
	Refrigerant pre-charged		kg	2.5
	Pre-charged line length		m	20
Working temp.	Additional gas charge		g/m	45
	Cooling (Min-Max)		°C	-15 to +50
	Heating (Min-Max)		°C	-20 to +24

HIGH STATIC DUCTED



ADH105H1ERG
 ADH125H1ERG
 ADH140H1ERG
 ADH160H1ERG



Outdoor Unit
1U105N1ERG

Outdoor Unit
1U125P1ERG
1U140P1ERG
1U160P1ERG



YR-E17



10.5kW, 12.5kW, 14.0kW & 15.5kW

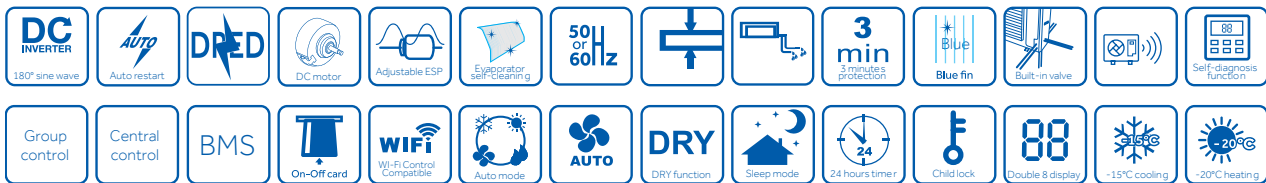

Model		Indoor unit		ADH105H1ERG	ADH125H1ERG	ADH140H1ERG	ADH160H1ERG
		Outdoor unit		1UH105N1ERG	1UH125P1ERG	1UH140P1ERG	1UH160P1ERG
Nominal performance data	Rated capacity	Cooling	kW nom (min-max)	10.5 (2.5-11.0)	12.5 (3.5 ~ 15.0)	14 (3.5 ~ 15.0)	15.5 (3.5-17.5)
		Heating	kW nom (min-max)	11.5 (2.5 ~ 12)	14 (4.0 ~ 18)	16 (6.0 ~ 19.0)	18.0 (6.0-20.0)
	Rated power input	Cooling	kW nom (min-max)	3.00 (0.5 ~ 5.3)	3.57 (1.0 ~ 6.5)	4.11 (2.0 ~ 7.2)	4.83 (2.0-7.2)
		Heating	kW nom (min-max)	3.10 (0.5 ~ 5.3)	3.88 (1.0 ~ 6.5)	4.40 (2.0 ~ 7.2)	5.13 (2.0-7.2)
	EER			3.5	3.5	3.4	3.21
COP			3.7	3.6	3.6	3.5	
Indoor Unit							
Electrical Parameters	Power supply		Ph/V/Hz	1/230/50/60			
	Power Input		Watt	540	550	600	600
Performance	Air flow (H/M/L/LL)		m ³ /h	2880/2380/1880/1380	3250/2750/2250/1850	3600/3100/2600/2100	4000/3400/2800/2200
			l/s	800/660/520/380	900/760/620/510	1000/860/720/580	1115/945/780/615
	ESP		pa	37-210			
	Sound pressure level (H/M/L)		dB(A)	45/41/37/33	47/44/42/39	49/46/43/40	51/47/44/40
Installation	External dimensions (WxDxH)		mm	1350x490x425			
	Shipping dimensions (WxDxH)		mm	1565x725x510			
	Net/Shipping weight		kg	59/70	61/72	61/72	61/72
	Supply Air Flange		mm	306 x 1046			
	Return Air Flange		mm	353 x 1164			
	Wired Controller		Standard	YR-E17			
	Wireless Controller		optional	YR-HBS01/RE-02			
Outdoor Unit							
Electrical Parameters	Power supply		Ph/V/Hz	1/230/50			
	Rated Amps	Cooling	Amp	13.3	16.5	18.5	21
		Heating	Amp	13.7	17.5	19.8	21.5
	Maximum Amps	Cooling	Amp	23.2	30	32	32
Heating		Amp	23.2	30	32	32	
Performance	Air flow (H)		m ³ /h	4000	6500	7000	7500
	Sound power level		dB(A)	68	69	70	73
	Sound pressure level		dB(A)	52	52	53	54
Installation	External dimensions (HxWxD)		mm	965x950x370	1350x950x370		
	Shipping dimensions (HxWxD)		mm	1095x1050x450	1500x1090x480		
	Net/Shipping weight		kg	82/94	105/118	108/121	105/118
	Compressor type			Twin rotary			
	Refrigerant type			R410A			
	Refrigerant liquid pipe		mm	9.52			
	Refrigerant gas pipe		mm	15.88			
	Max pipe length		m	50	75		
	Max drop between I.U.&O.U		m	30			
	Pre Charge of refrigerant		kg	2.5	3.7	3.7	3.7
	Pre-charged line length		m	20	30	30	30
Additional gas charge		g/m	45	45	45	45	
Working Temperature	Cooling (Min-Max)		°C	-15 ~ +50			
	Heating (Min-Max)		°C	-20 ~ +24			



Individual flap control

The four outlet louvers can be controlled individually by the controller, providing maximum comfort throughout the room.

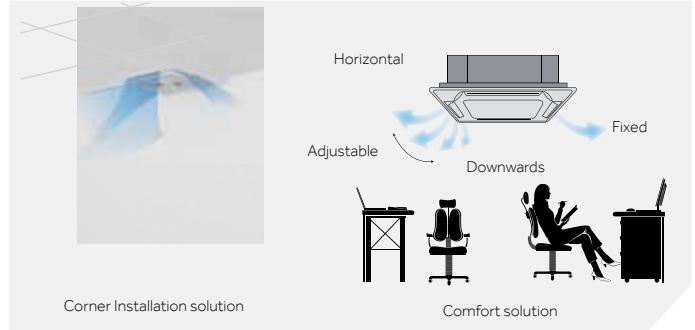

Round flow air supply

Air supply in all directions to improve air distribution



Hidden LCD Display

Hidden LCD display design. Green display for cooling, red display for heating.

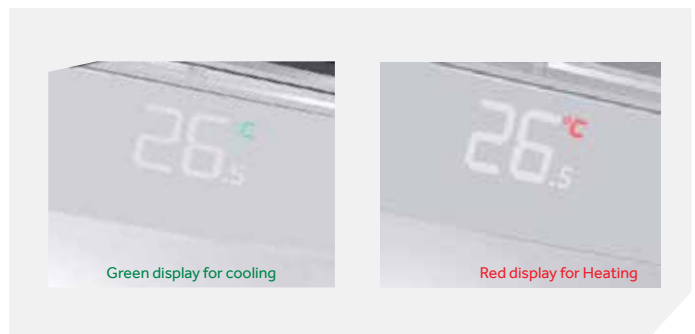

ABS Panel plastics

The round flow cassette panel is manufactured from high grade ABS plastic designed to resist yellowing over time..

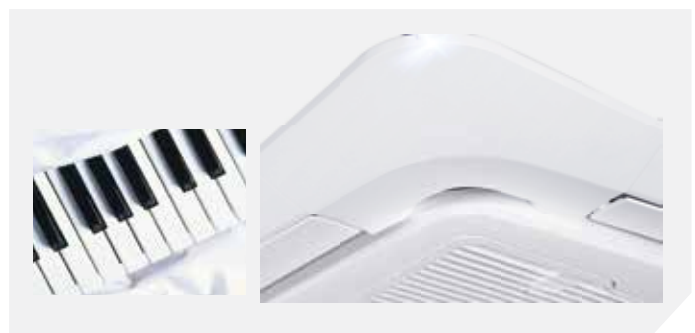

CASSETTE

High lift drain pump

Pump can lift up to 1000mm.

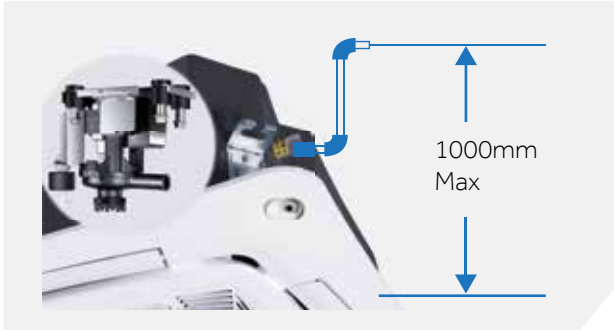

Moving eye intelligent panel (optional)

Panel PB-9500MB has an eye that can detect movement in the room.



Fresh Air Inlet

Pre-set fresh air inlet can introduce the outside fresh air into the room to improve the indoor air quality.



Mode of operation.

1. Follow or Evade: The airflow can be set to "follow or evade" to reduce or increase draft to improve comfort level.
2. Absence: Temperature set-point will be adjusted up or down 1 degree every 30 minutes if no movement is detected.

Follow



Evade

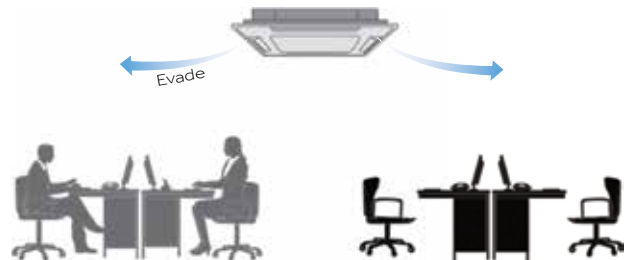

High Ceiling Mode ⁽¹⁾

Indoor unit can be installed 4.5 meters high.

⁽¹⁾Wired controller YR-E16A required

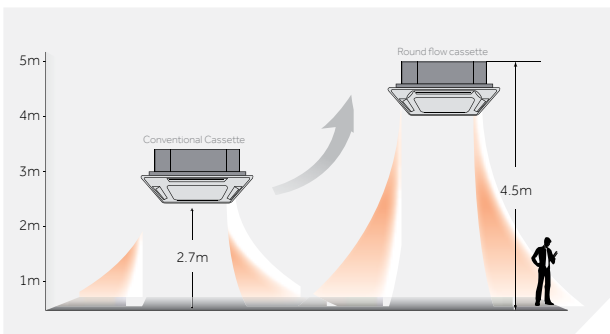

Installer friendly

The electrical panel can be removed with one screw.

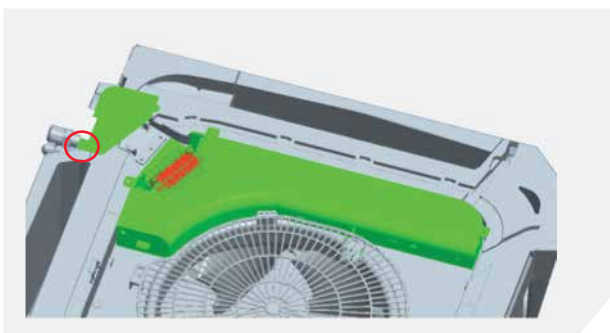

Absence

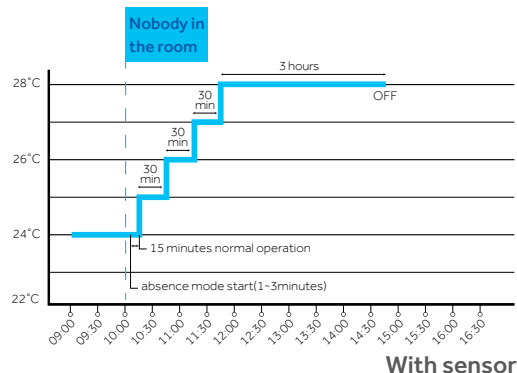

CASSETTE MODELS



ABH071H1ERG ABH090H1ERG ABH105H1ERG



YR-HBS01



Round way airflow
4 way independent airflow
Moving eye panel (PB-950MB)
optional



Model		Indoor unit		ABH071H1ERG	ABH090H1ERG	ABH105H1ERG
		Outdoor unit		1UH071N1ERG	1UH090N1ERG	1UH105N1ERG
Nominal performance data	Nominal capacity	Cooling	kW nom (min-max)	7.1 (2.0-8.0)	9.0 (2.5-10)	10.0 (2.5-11)
		Heating	kW nom (min-max)	7.8 (2.0-9.0)	10.1 (2.5-11)	10.6 (2.5-11.3)
	Rated power input	Cooling	kW nom (min-max)	1.89 (0.4-3.2)	2.56 (0.5-3.5)	2.99 (0.5-4.0)
		Heating	kW nom (min-max)	2.0 (0.4-3.2)	2.69 (0.5-3.5)	2.86 (0.5-4.0)
	EER	W/W	3.75	3.52	3.34	
	COP	W/W	3.9	3.75	3.7	
Energy class (Cooling/Heating)				2.5 star / 3 star	2 star / 2.5 star	1.5 star / 2.5 star
Indoor Unit						
Electrical	Power supply	Ph/V/Hz		1/220-240/50/60		
Performance	Air flow (H/M/L)	m ³ /h		1260/1070/820/680	1470/1260/1050/940	1680/1530/1320/1190
		L/S		350/295/225/185	405/350/290/260	465/425/365/330
	Sound power level (H/M/L)	dB(A)		52	57	62
Installation	Sound pressure level (H/M/L)	dB(A)		36/33/29/26	41/36/33/29	45/42/38/34
	External dimensions (W/D/H)	mm		840/840/246		
	Shipping dimensions (W/D/H)	mm		990/990/310		
	Weight Net/Shipping	kg		31/36		
	Wireless Controller	Standard		YR-HBS-01		
Panel	Wired Controller	optional		YR-E17 / YR-E16A (7 day time clock)		
	Panel Model			PB-950KB (standard panel) PB-950MB (Movement sensor panel)		
	External dimensions(W/D/H)	mm		950x950x50		
	Shipping dimensions(W/D/H)	mm		1000x1000x110		
	Weight Net/Shipping	kg		6.5/9		
Outdoor Unit						
Electrical	Power supply	Ph/V/Hz		1/220-240/50/60		
	Rated Current	Cooling	Amps	8.7	11.6	13.6
		Heating	Amps	9.1	11.9	12.7
Maximum Current	Amps		17.5	19.2	20.0	
Performance	Air flow (H)	m ³ /h		3200	3500	4000
		L/S		885	970	1110
	Sound power level	dB(A)		64	66	68
	Sound pressure level	dB(A)		47	50	52
Installation	External dimensions (H/W/D)	mm		965x950x370		
	Shipping dimensions (H/W/D)	mm		1095x1050x450		
	Weight Net/Shipping	kg		80/92		82/94
	Compressor type			Rotary		
	Refrigerant type			R410A		
	Refrigerant liquid pipe	mm		9.52		
	Refrigerant gas pipe	mm		15.88		
	Max pipe length	m		50		
	Max drop between I.U.&O.U	m		30		
	Refrigerant pre- charged	kg		2.5		
	Pre-charge line length	m		20		
Additional gas charge	g/m		45			
Working temp.	Cooling(Min-Max)	°C		-15 to +50		
	Heating(Min-Max)	°C		-20 to +24		

CASSETTE MODELS



ABH125K1ERG ABH140K1ERG



YR-HBS01



Round way airflow
4 way independent airflow
Moving eye panel (PB-950MB)
optional

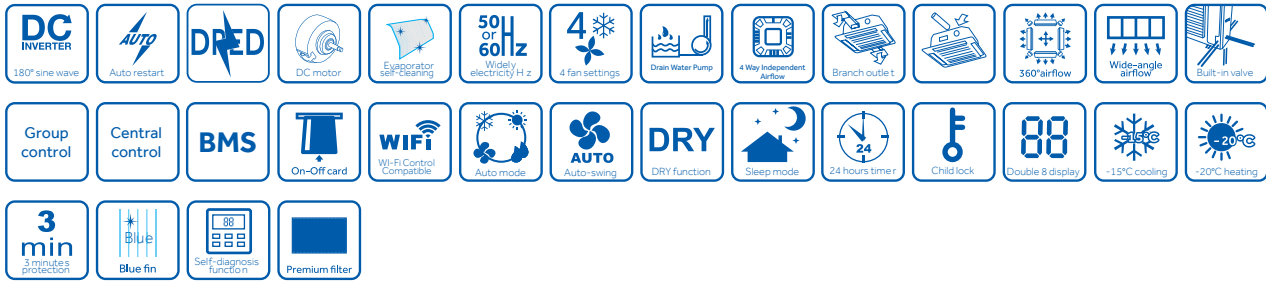

Model		Indoor unit		ABH125K1ERG	ABH125K1ERG	ABH140K1ERG	
		Outdoor unit		1UH125P1ERG	1UH125P1ERK	1UH140P1ERK	
Nominal performance data	Nominal capacity	Cooling	kW nom (min-max)	12.5 (3.5-14.5)	12.5 (3.5-14.5)	13.4 (3.5-15.5)	
		Heating	kW nom (min-max)	13.1 (4-17)	13.1 (4-17)	14.5 (4.0-18.0)	
	Rated power input	Cooling	kW nom (min-max)	3.67 (1.0-6.0)	3.67 (1.0-6.0)	4.05 (1.0-6.5)	
		Heating	kW nom (min-max)	3.71 (1.0-6.0)	3.71 (1.0-6.0)	4.11 (1.2-6.8)	
	EER	WxW	3.41	3.41	3.31		
COP	WxW	3.53	3.53	3.53			
Energy class (Cooling/Heating)				2 star x 2 star	-	-	
Indoor Unit							
Electrical	Power supply	PhxVxHz		1x220-240x50x60			
Performance	Air flow (H/M/L)	m3/h		1950/1600/1440/1200	1950/1600/1440/1200	1950x1600x1440x1200	
		L/S		540/440/400/330	540/440/400/330	540x440x400x330	
	Sound power level (H/M/L)	dB(A)		64	64	64	
	Sound pressure level (H/M/L)	dB(A)		47/44/38/34	47/44/38/34	47x44x38x34	
Installation	Eternal dimensions (W/D/H)		mm		840/840/288		
	Shipping dimensions (W/D/H)		mm		990/990/380		
	Weight Net/Shipping		kg		32/38		
	Wireless Controller		Standard		YR-HBS-01		
Wired Controller		optional		YR-E17 / YR-E16A			
Panel	Panel Model		PB-950KB (standard panel) PB-950MB (Movement sensor panel)				
	External dimensions (WxDxH)		mm		950x950x50		
	Shipping dimensions (WxDxH)		mm		1000x1000x110		
	Weight Net/Shipping		kg		6.5/9		
Outdoor Unit							
Electrical	Power supply		Ph/V/Hz		1/220-240 / 50-60		
	Rated Current	Cooling	Amps	17.0	6.1	6.8	
		Heating	Amps	17.2	6.2	7.0	
Maximum Current		Amps		30.0	10.8	11.0	
Performance	Air flow (H)	m3xh		6500		7000	
		L/S		1805		1940	
	Sound power level	dB(A)		69	70	70	
	Sound pressure level	dB(A)		52	53	53	
Installation	External dimensions (HxWxD)		mm		1350x950x370		
	Shipping dimensions (HxWxD)		mm		1500x480x1090		
	Weight Net/Shipping		kg		105/118	108/121	108x121
	Compressor type				Rotary		
	Refrigerant type				R410A		
	Refrigerant liquid pipe		mm		9.52		
	Refrigerant gas pipe		mm		15.88		
	Max pipe length		m		75		
	Max drop between I.U.&O.U		m		30		
	Refrigerant pre- charged		kg		3.7		
	Pre-charged line length		m		30		
	Additional gas charge		qxm		45		
Working temp.	Cooling (Min-Max)		°C		-15 to +50		
	Heating (Min-Max)		°C		-20 to +24		

DRAWINGS

OUTDOOR UNITS

1UH071N1ERG 1UH090N1ERG 1UH105N1ERG

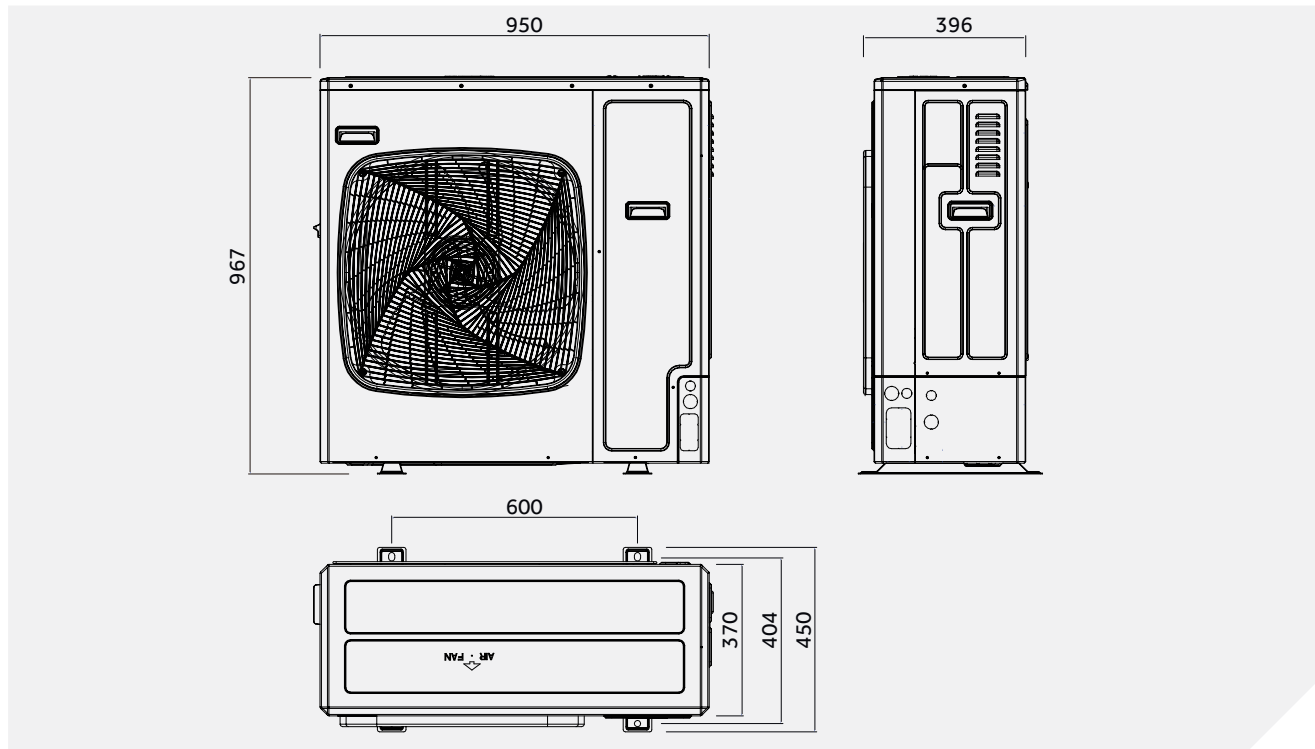

1UH125P1ERG 1UH140P1ERG 1UH160P1ERG 1UH140P1ERG 1UH140P1ERK

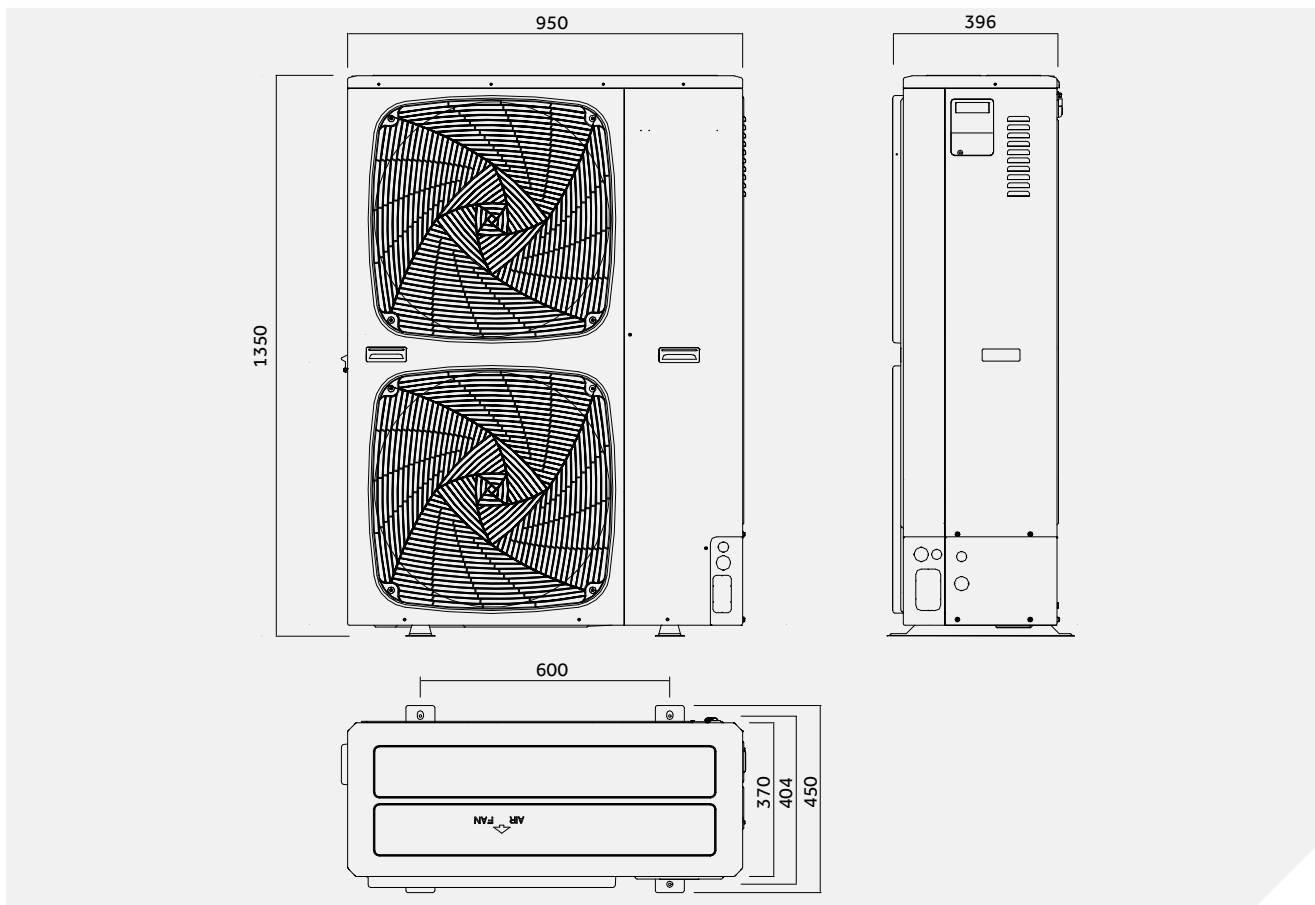

DRAWINGS

INDOOR UNITS

ADH105H1ERG ADH125H1ERG ADH140H1ERG ADH160H1ERG

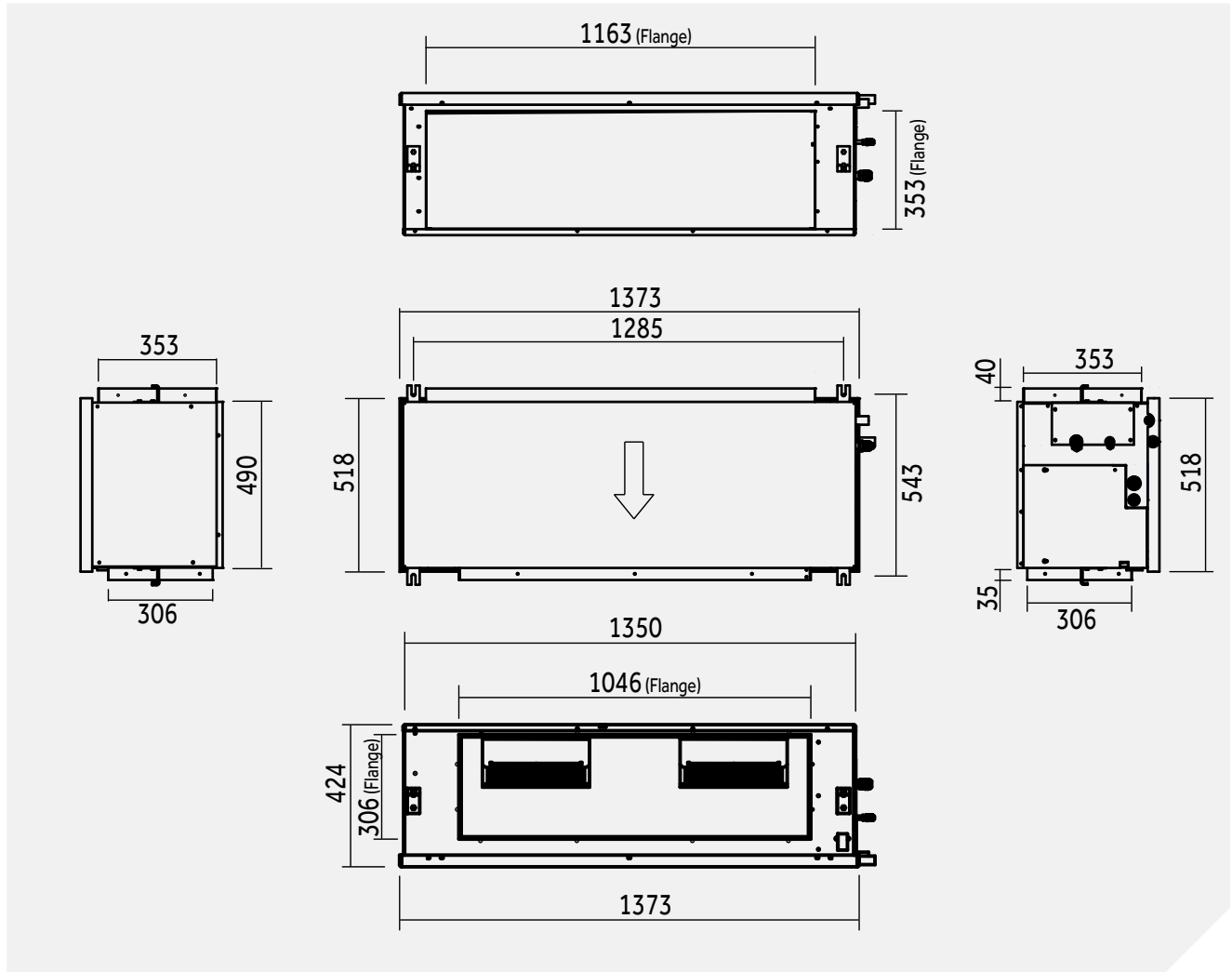

DRAWINGS

INDOOR UNITS

LOW PROFILE DUCTED

ADH071M1ERG ADH090M1ERG ADH071M3ERG

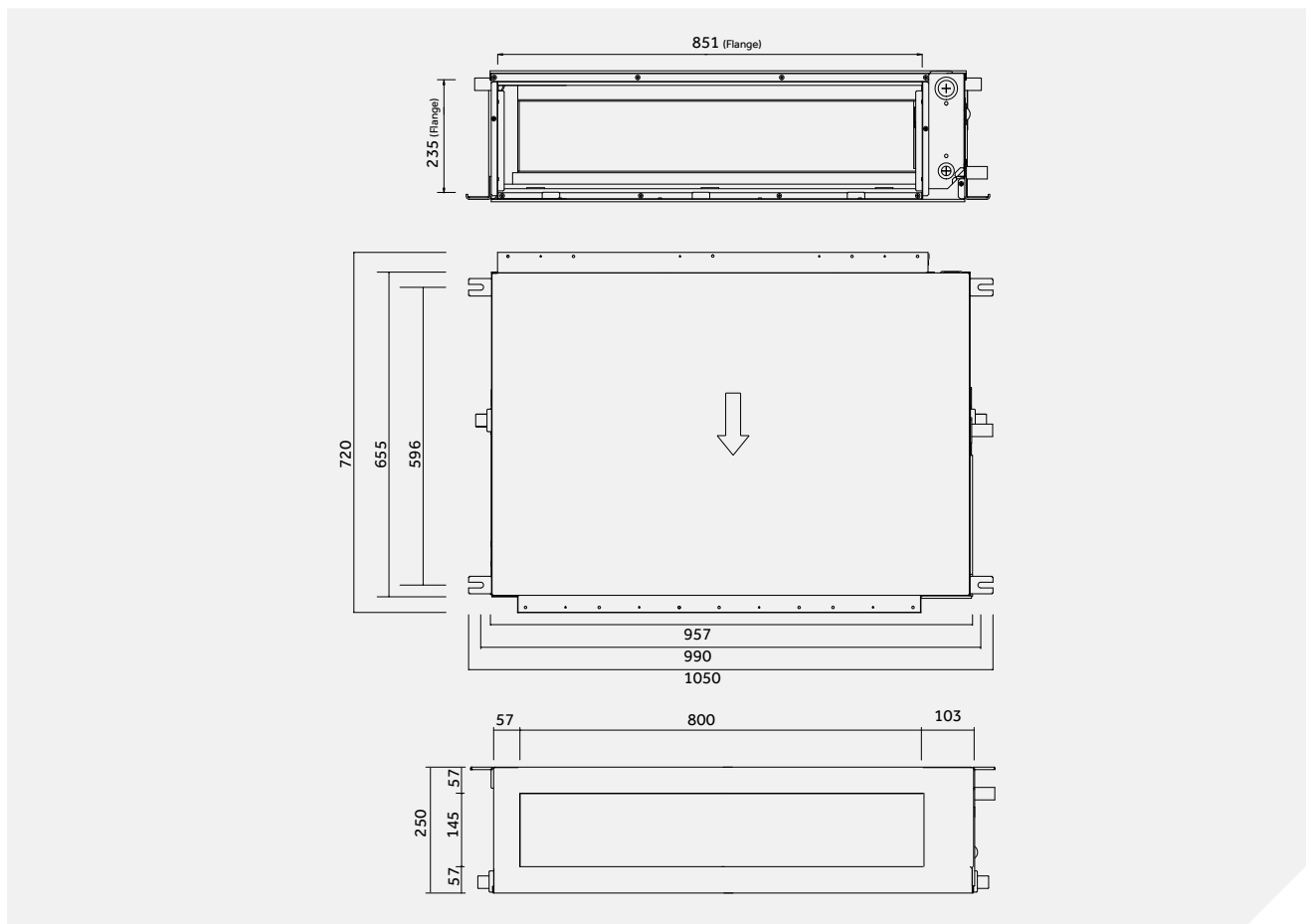

ADH105M1ERG ADH125M1ERG ADH140M1ERG

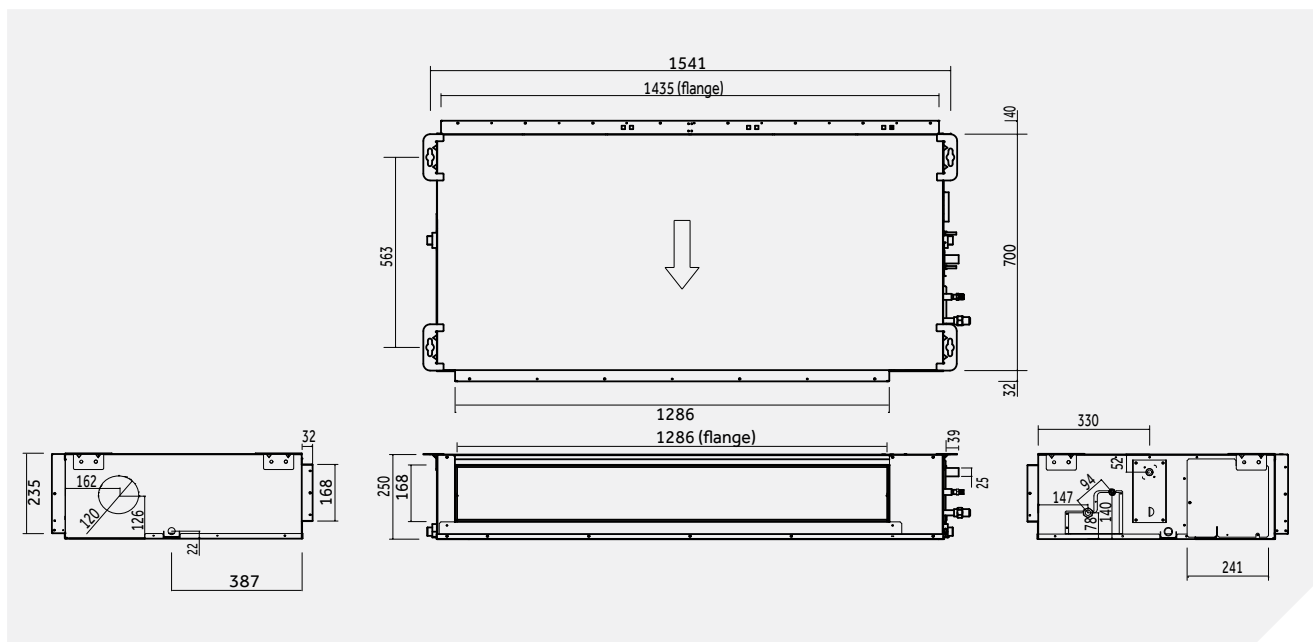

DRAWINGS

INDOOR UNITS

CASSETTE

ABH071H1ERG ABH090H1ERG ABH105H1ERG

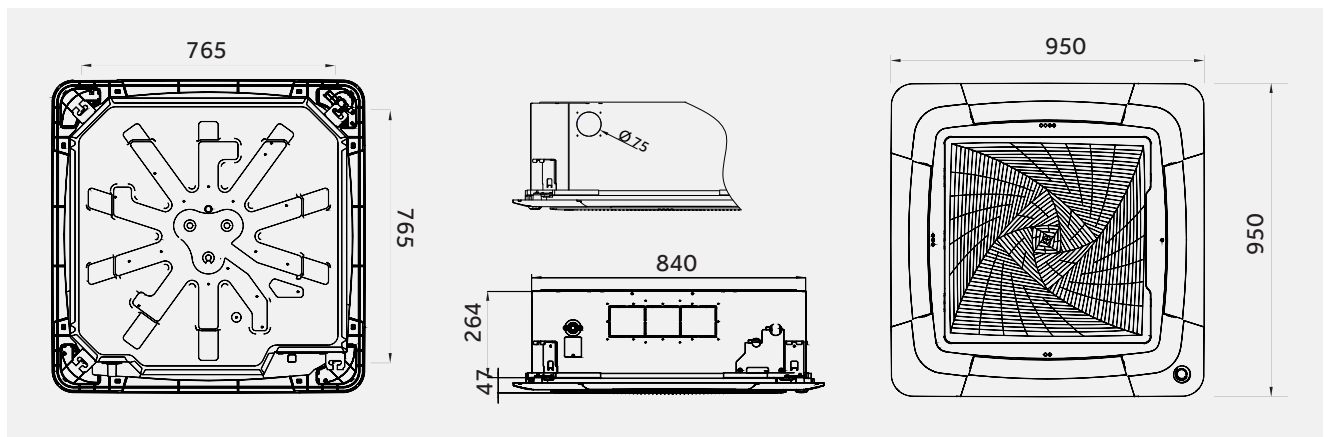

ABH125K1ERG ABH140K1ERG

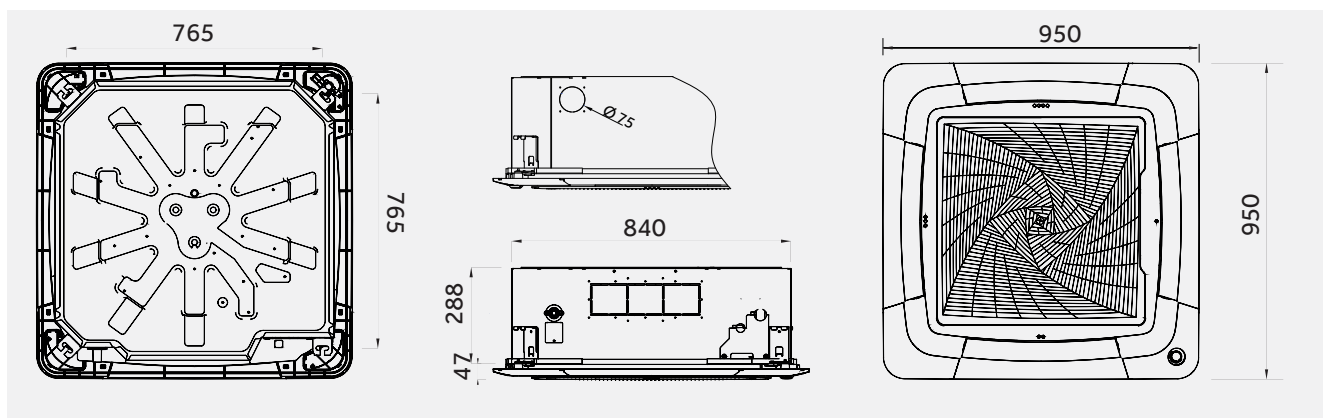

CONTROL SYSTEM

YR-E17

- Supplied with Ducted unit.
- 24 Hr Timer / Clock
- Small, Simple and Smart design, 86x86x13mm
- Touch screen with back-light
- On/Off, Mode, Fan speed, Temperature setting, Swing.
- Individual control & Group control (Max 16 indoor units)
- Fahrenheit / Celsius selectable; Sensitivity $\pm 0.5^{\circ}\text{C}$
- Static pressure setting.



YR-E16A

- Optional purchase (upgrade)
- 7 Day Timer / Clock
- Large touch button with colour LCD, with back-light.
- Error display in listed in Year/Month/Date format.
- On/Off, Mode, Fan speed, Temperature setting, Swing
- Individual control & Group control (Max 16 indoor units)
- Fahrenheit / Celsius selectable; Sensitivity $\pm 0.5^{\circ}\text{C}$
- Static pressure setting



Wireless control for Ducted system

- RE-02 Infrared receiver control for duct type indoor unit.
- Requires one YR-HD



(Part H0010401511)

YR-HBS-01

- Supplied with Cassette
- Oversized display with oversized buttons for easy use.
- Temperature setting of 0.5 degree increments
- Individual cassette louver control for round way cassette
- Follow and eade function for use with PB-950MB panel.



KZW-W001

- Wi-Fi control
- APP available for Apple and Android
- Weekly timer
- Connect multiple units one APP



CENTRAL CONTROL SYSTEM

Y CZ-G001

- Central control (Max 32 indoor units)
- Individual control, Group control
- Large touch keys
- 7 day timer.
- Unit name & Group name free setting. Four background available (mall, hotel, office, home)



Y CZ-A004

- Central control (Max 256 indoor units)
- Individual control, Group control
- 7-inch Touch colour screen, with back-light
- Schedule control
- Indoor units information.



ACTUAL SIZE

YR-E17 pictured. Screen icons subject to change as the controller will self adapt to the indoor unit connected.

Summary of features

- Touch Screen
- Backlit display for easier viewing.

Summary of buttons

1. On/Off: turn system on and off.
2. Mode: Change mode of operation from Intelligent - Cooling - Heating - Fan - Dry
3. Fan: Alter airflow High-Medium-Low
4. Temperature up/down. Adjust the set-point temperature is 0.5 degree increments
5. Timer: Select Timer ON, Timer OFF, Timer ON/OFF.
6. Set: To enter special functions like swing, four (4) way louvre adjustment (cassette model).



For Haier Appliances

Australia 1300 729 948 | haier.com.au

New Zealand 0800 424 372 | haier.co.nz

Haier
Air Conditioning

Important notice of Disclosure: Copyright © Fisher & Paykel Appliances 2017. All rights reserved.
The product dimensions and specifications in this brochure apply to the specific products and models described at the date of issue. Under our policy of continuous product improvement, these dimensions and specifications may change at any time. You should therefore check with your dealer or Haier's Customer Care Centre to ensure this flyer correctly describes the products currently available.

Fisher & Paykel Australia Pty Ltd, Level 1, 1 Eden Park Drive, Macquarie Park, NSW 2113.
Phone Customer Care: 1300 729 948 Email: customer.care@haier.com.au

Fisher & Paykel Appliances Ltd, 78 Springs Road, East Tamaki, Auckland 2013.
Phone Customer Care: 0800 424 372. Email: customer.care@haier.co.nz

Version 20182

CONTACT US

CONSOLIDATEDENERGY.COM.AU

VIC

p. (03) 9794 8250

e. vic@consolidatedenergy.com.au

NSW

p. (02) 9625 0915

e. nsw@consolidatedenergy.com.au

QLD

p. (07) 3271 4070

e. qld@consolidatedenergy.com.au

WA

p. (08) 6270 6400

e. wa@consolidatedenergy.com.au

SA

p. (08) 8445 8111

e. sa@consolidatedenergy.com.au

ACT

p. (02) 6260 1455

e. act@consolidatedenergy.com.au